

**18. FLOOR STANDING TYPE
PACKAGED AIR-CONDITIONER
(Split system, Air to air)
heat pump type**

FDF508HES-SB

CONTENTS

18.1 GENERAL INFORMATION	603
18.1.1 Specific features	603
18.1.2 How to read the model name	603
18.2 SELECTION DATA	604
18.2.1 Specifications	604
18.2.2 Range of usage & limitations	605
18.2.3 Exterior dimensions	606
18.2.4 Exterior appearance	608
18.2.5 Piping system	609
18.2.6 Selection chart	610
18.2.7 Noise level	611
18.3 ELECTRICAL DATA	612
18.3.1 Electrical wiring	612
18.4 OUTLINE OF OPERATION CONTROL BY MICROCOMPUTER	613
18.5 APPLICATION DATA	613
18.5.1 Installation of indoor unit	614
18.5.2 Installation of outdoor unit	616
18.6 MAINTENANCE DATA	616

18.1 GENERAL INFORMATION

18.1.1 Specific features

- (1) Less refrigerant charge amount due to use of double phase refrigerant flow system. The total refrigerant charge amount has been reduced by more than 50%.
- (2) The indoor outdoor interconnection signal wiring has been done away with. The microcomputer chip is installed in the indoor and outdoor unit. There is no need for the unit to communicate between the outdoor and indoor units so the unit is more resistant to electromagnetic noise thus the incidence of microcomputer malfunction has been reduced. The compressor in the outdoor unit has its own self protection function, that reacts according to abnormal high pressure and excessive high temperature.
- (3) All models have service valves protruding from the outdoor unit for faster flare connection work in the field.
- (4) The connecting piping can have a 4-way off-take.
The direction of the off-take can meet the installation conditions. Selection can be made from among all directions: left, right, rear-right and floor pull-out. This provides a wide range of installation freedom.
- (5) Auto-Swing Design Used.
Adjustment is automatic to a maximum of 90° in the left and right direction. Up/down adjustment is done manually. Adjustment can be made to 20° in the up direction and 30° in the down direction.

18.1.2 How to read the model name

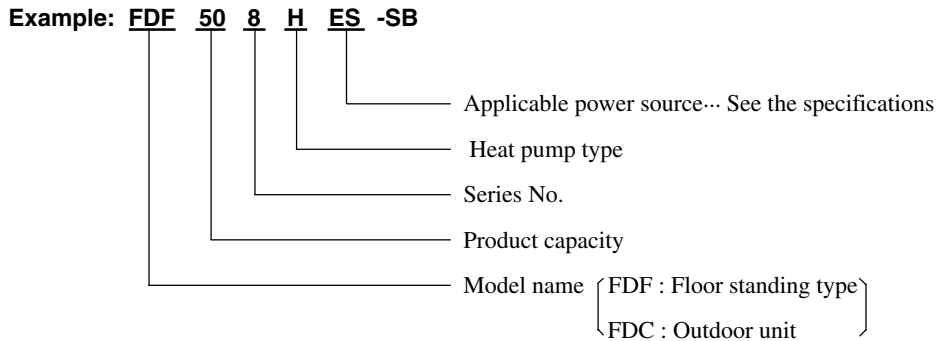

18.2 SELECTION DATA

18.2.1 Specifications

Model FDF508HES-SB

Item		Model	FDF508HES-SB	
			FDF508H	FDC508HES3B
Nominal cooling capacity⁽¹⁾		W	12500	
Nominal heating capacity⁽¹⁾		W	14000	
Power source			3 Phase, 380V, 50Hz	
Operation data ⁽³⁾	Cooling input	kW	5.42	
	Running current (Cooling)	A	9.8	
	Power factor (Cooling)	%	84	
	Heating input	kW	4.97	
	Running current (Heating)	A	9.3	
	Power factor (Heating)	%	81	
	Inrush current (L.R.A)	A	74	
Noise level ⁽⁴⁾		dB(A)	Hi: 49 Lo: 45	55
Exterior dimensions				
Height × Width × Depth		mm	1850 × 600 × 350	1250 × 920 × 340
Net weight		kg	46	101
Refrigerant equipment				
Compressor type & Q'ty			—	GU-A5570ES41 × 1
Motor		kW	—	3.75
Starting method			—	Line starting
Heat exchanger			Louver fines & inner grooved tubing	Slitted fines & bare tubing
Refrigerant control			Capillary tube	
Refrigerant			R22	
Quantity		kg	—	1.9 [Pre-charged up to the piping length of 5m]
Refrigerant oil		ℓ	—	1.6 (BARREL FREEZE 32SAM)
Defrost control			IC controlled de-icer	
High pressure control			High pressure switch	
Air handling equipment				
Fan type & Q'ty			Sirocco fan × 1	Propeller fan × 2
Motor		W	130 × 1	65 × 2
Starting method			Line starting	Line starting
Air flow (Standard)		CMM	Hi: 28 Lo: 23	110
Fresh air intake			Unavailable	—
Air filter, Q'ty			Polypropylene net (washable)	—
Shock & vibration absorber			Rubber sleeve (for fan motor)	Rubber mount (for compressor)
Electric heater		W	—	40 (Crank case heater)
Operation control				
Operation switch			Control switch	— (Indoor unit side)
Electric heater			— (Can be incorporated: PTC Heater 2.2 kW)	—
Room temperature control			Thermostat by electronics	—
Safety equipment			Internal thermostat for fan motor Frost protection thermostat.	Internal thermostat for fan motor. Abnormal discharge temperature protection.
Installation data		mm		
Refrigerant piping size		(in)	Liquid line: φ9.52 (3/8") Gas line: φ19.05 (3/4")	
Connecting method			Flare piping	
Drain hose			(Connectable with VP20)	—
Insulation for piping			Necessary (both Liquid & Gas lines)	
Accessories			Mounting kit.	
Optional parts			Electric heater	

Notes (1) The data are measured at the following conditions.

Item	Indoor air temperature		Outdoor air temperature		Standards
	DB	WB	DB	WB	
Cooling	27°C	19°C	35°C	24°C	ISO-T1 JIS B8616
Heating	20°C	—	7°C	6°C	

(2) This packaged air conditioner is manufactured and tested in conformity with the following standard. ISO-T1 "UNITARY AIR CONDITIONERS"

(3) The operation data indicate when the air-conditioner is operated at 380V 50Hz.

(4) Indicators the value at mild mode.

18.2.2 Range of usage & limitations

Item	Model FDF508HES-SB
Indoor return air temperature (Upper, lower limits)	Refer to the selection chart
Outdoor air temperature (Upper, lower limits)	
Refrigerant line (one way) length	Max. 50 m
Vertical height difference between outdoor unit and indoor unit	Max. 30 m (Outdoor unit is higher) Max. 15 m (Outdoor unit is lower)
Power source voltage	Rating \pm 10%
Voltage at starting	Min. 85% of rating
Frequency of ON-OFF cycle	Max. 10 times/h
ON and OFF interval	Min. 3 minutes

18.2.3 Exterior dimensions

(1) Indoor unit Model FDF508H

Unit: mm

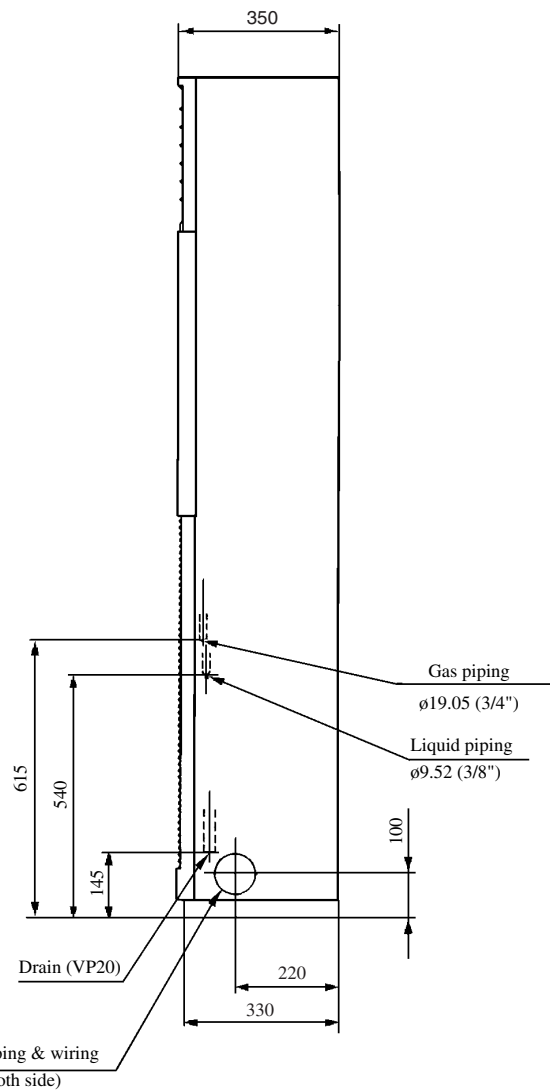
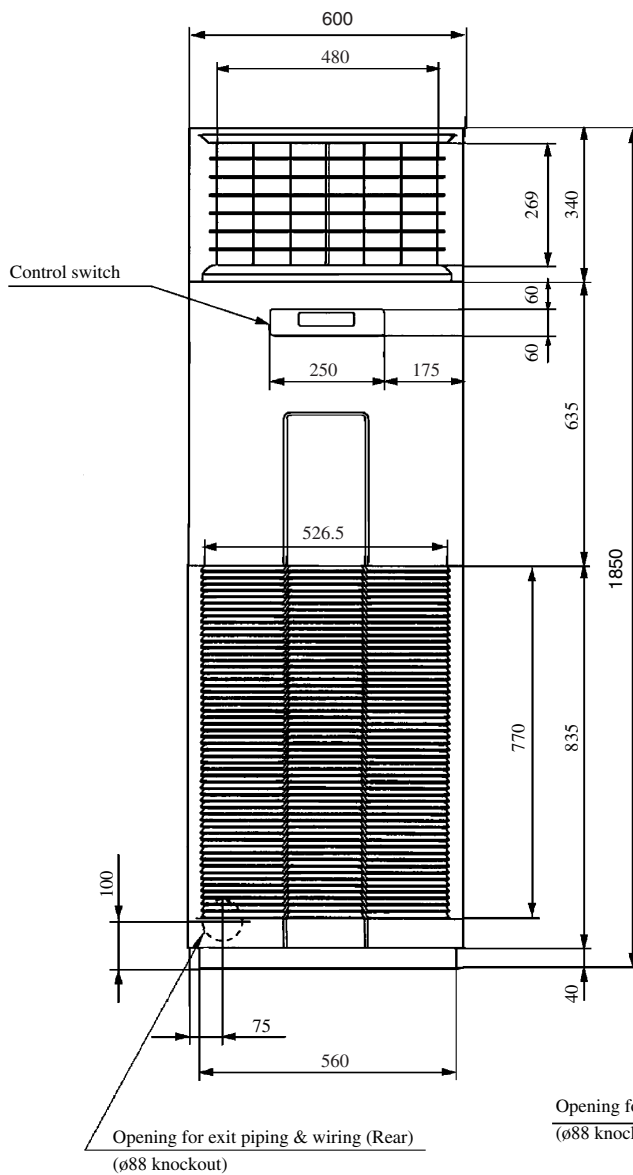
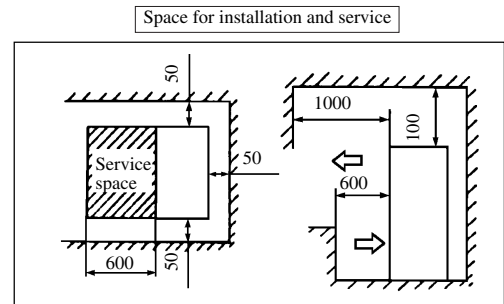
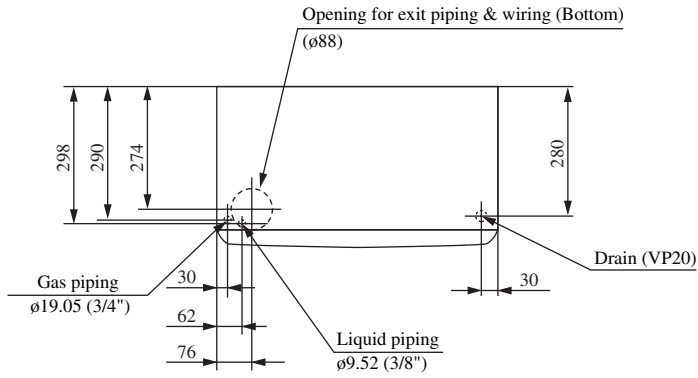

(2) Outdoor unit
Model FDC508HES3B

Unit: mm

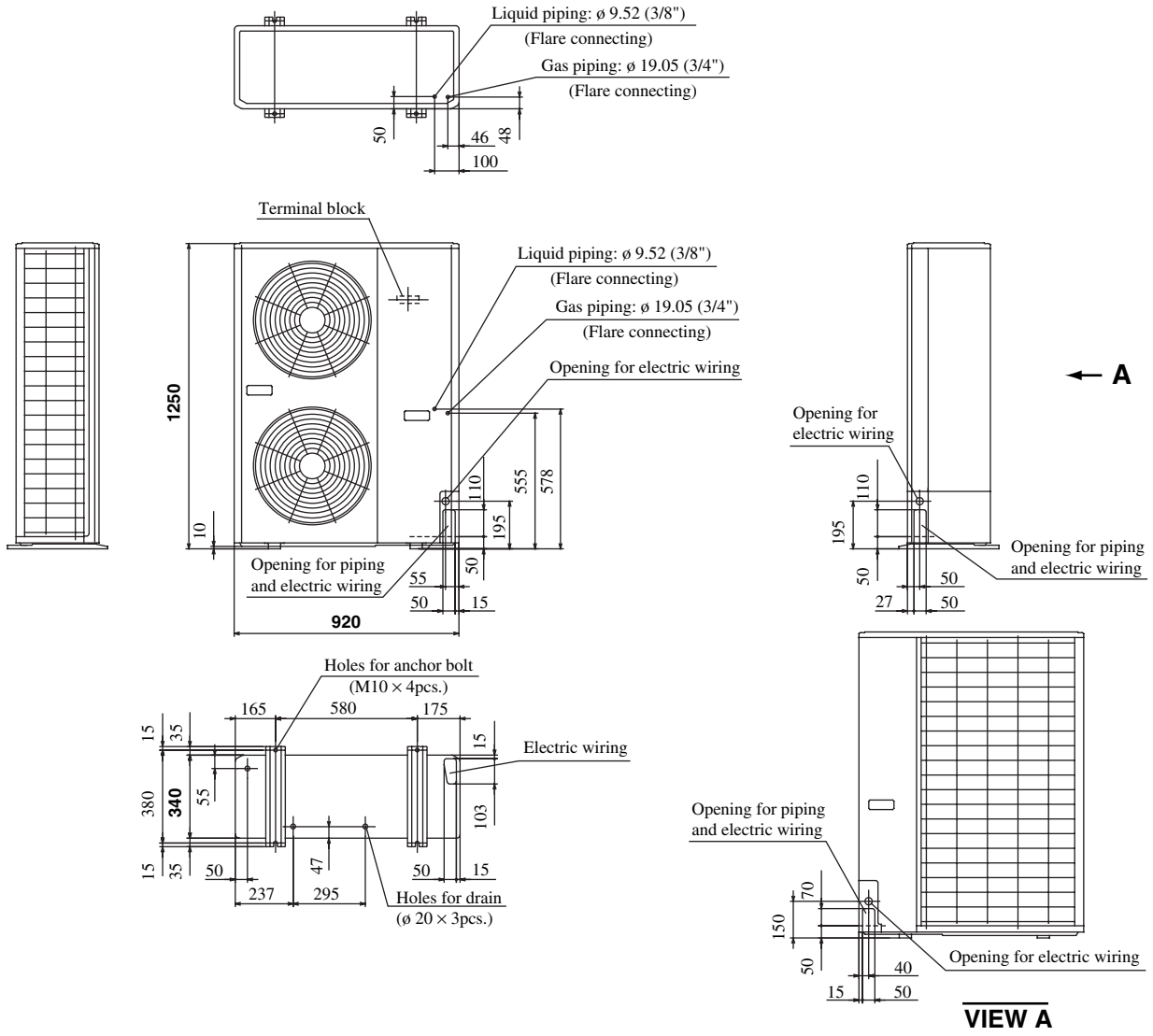

Required space for service and air flow

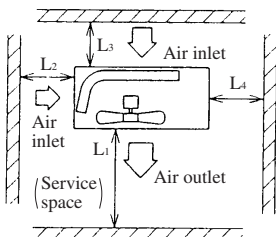

Minimum allowable space to the obstacles

Unit:mm

Mark	Installation type	Unit:mm		
		I	II	III
L ₁	Open	Open	Open	500
L ₂	300	5	Open	Open
L ₃	150	300	150	150
L ₄	5	5	5	5

Notes

- (1) Avoid the location where four sides are entirely surrounded by walls.
- (2) Fix the unit by anchor bolts without fail. Restrict the protrusion length of anchor bolt to 15 mm and under.
- (3) When strong wind blows against the unit, direct the discharge port at a right angle to the wind direction.
- (4) Secure the space of 1 m and over at the top of unit.
- (5) Make the height of obstruction wall in front of discharge port lower than the height of unit.

18.2.4 Exterior appearance

(1) Indoor unit

Model FDF508H

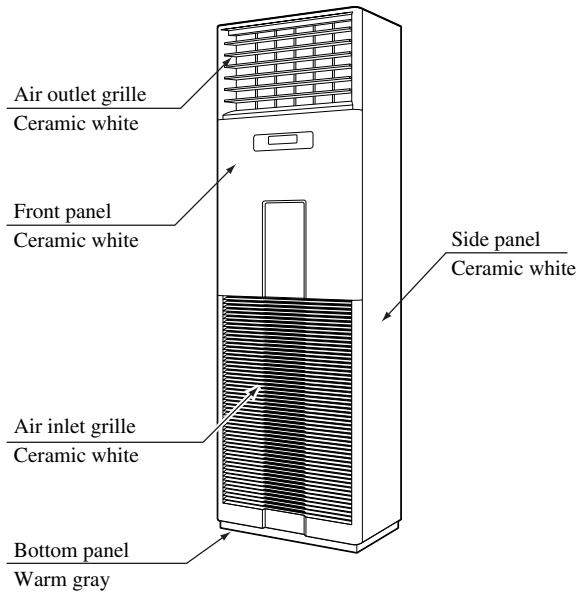

(2) Outdoor unit

Model FDC508HES3B

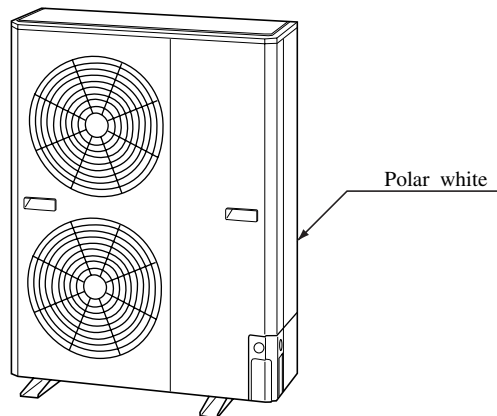

18.2.5 Piping system

Model FDF508HES-SB

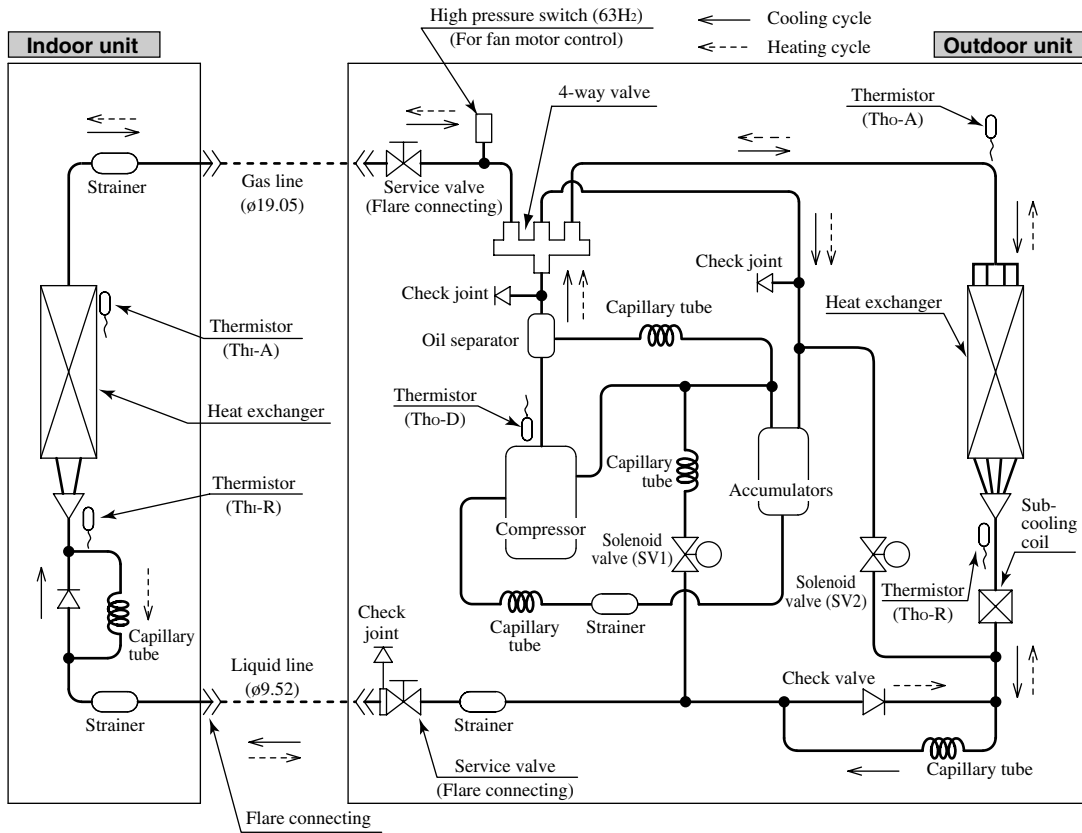

Preset point of the protective devices

Parts name	Mark	Equipped unit	FDF508HES-SB
Thermistor (for protection over loading in heating)	Thi-R	Indoor unit	OFF 68 °C
			ON 61 °C
Thermistor (for frost prevention)	Thi-R	Indoor unit	OFF 2.5 °C
			ON 10 °C
Thermistor (for detecting discharge pipe temp.)	Tho-D	Outdoor unit	OFF 135 °C
			ON 90 °C
Thermistor (for detecting heat exchanger temp.)	Tho-R	Outdoor unit	OFF 70 °C
			ON 60 °C
High pressure switch (for controlling FMO)	63H2	Outdoor unit	OFF 2.50MPa
			ON 2.06MPa

18.2.6 Selection chart

Correct the cooling and heating capacity in accordance with the conditions as follows. The net cooling and heating capacity can be obtained in the following way.

Net capacity = Capacity shown on specification × Correction factors as follows.

(1) Coefficient of cooling and heating capacity in relation to temperatures

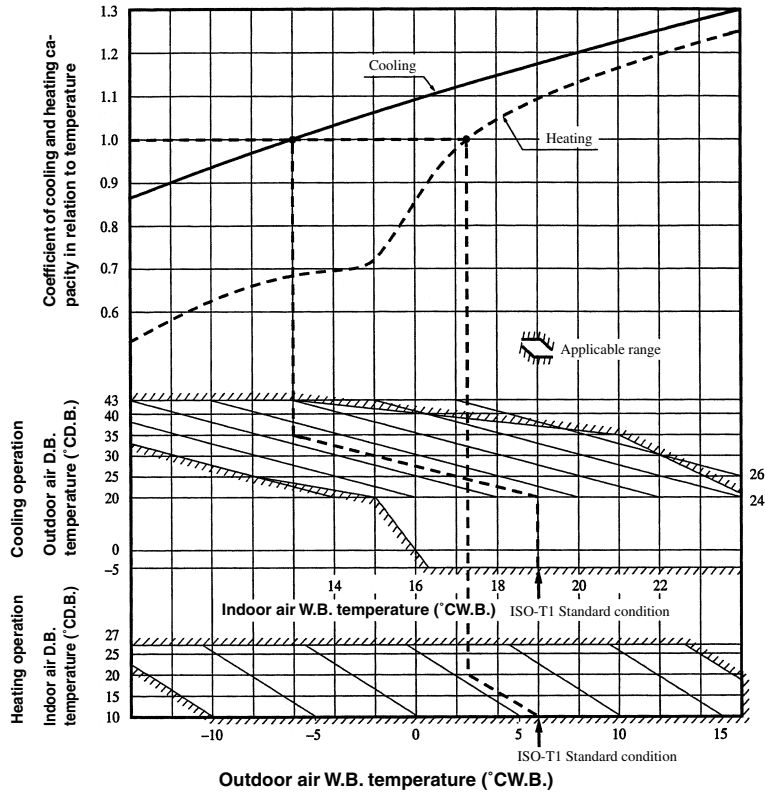

(a) Table of bypass factor

Item		Model	FDF508HES-SB
Air flow	High		0.032
	Low		0.022

(2) Correction of cooling and heating capacity in relation to air flow rate control (fan speed)

Coefficient: 1.00 at High, 0.95 at Low

(3) Correction of cooling and heating capacity in relation to one way length of refrigerant piping

It is necessary to correct the cooling and heating capacity in relation to the one way equivalent piping length between the indoor and outdoor units.

Equivalent piping length ⁽¹⁾ m	7.5	10	15	20	25	30	35	40	45	50	55
Heating	1.0	1.0	1.0	1.0	1.0	0.998	0.998	0.993	0.993	0.988	0.988
Cooling	1.0	0.995	0.980	0.970	0.955	0.945	0.930	0.920	0.905	0.895	0.880

Note (1) Equivalent piping length can be obtained by calculating as follows.

$[\phi 19.05(3/4")]$: Equivalent piping length = Real piping length + (0.15 × Number of bends in piping)

[Equivalent piping length < Limitation length of piping + 5m]

- (4) When the outdoor unit is located at a lower height than the indoor unit in cooling operation and when the outdoor unit is located at a higher height than the indoor unit in heating operation, the following values should be subtracted from the values in the above table.

Height difference between the indoor unit and outdoor unit in the vertical height difference	5m	10m	15m	20m	25m	30m
Adjustment coefficient	0.01	0.02	0.03	0.04	0.05	0.06

Piping length limitations

Item	Model	DFD508HES-SB
Max. one way piping length		50m
Max. vertical height difference		Outdoor unit is higher : 30m, Outdoor unit is lower : 15m

Note (1) Values in the table indicate the one way piping length between the indoor and outdoor units.

How to obtain the cooling and heating capacity

Example : The net cooling capacity of the model FDF508HES-SB with the air flow “High”, the piping length of 15m, the outdoor unit located 5m lower than the indoor unit, indoor wet-bulb temperature at 19.0 °C and outdoor dry-bulb temperature 35 °C is

$$\text{Net cooling capacity} = \frac{12500}{\text{DFD508HES-SB}} \times \frac{1.00}{\text{Air flow "High"}} \times \frac{(0.98 - 0.01)}{\text{Length 15m. Height difference 5m}} \times \frac{1.0}{\text{Factor by air temperatures}} = 12125 \text{ w}$$

18.2.7 Noise level

Notes (1) The data are based on the following conditions.

Ambient air temperature:
 Indoor unit 27°C DB, 19°C WB
 Outdoor unit 35°C DB,

Indoor unit
 Measured based on JIS B 8616
 Mike position as below

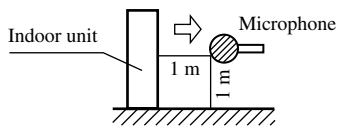

Outdoor unit
 Measured based on JIS B 8616
 Mike position: at highest noise level
 in position as below
 Distance from front side 1 m
 Height 1 m

- (2) The data in the chart are measured in an anechoic room.
 (3) The noise levels measured in the field are usually higher than the data because of reflection.

(1) Indoor unit

Model FDF508H

Noise level 49 dB (A) at HIGH
 45 dB (A) at LOW

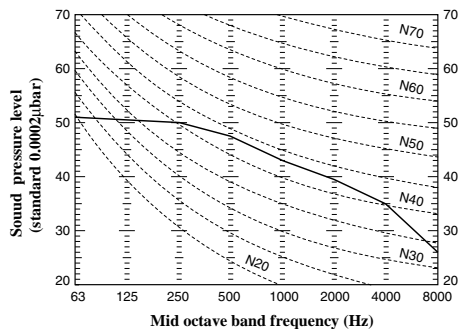

(2) Outdoor unit

Model FDC508HES3B

Noise level 55 dB (A)

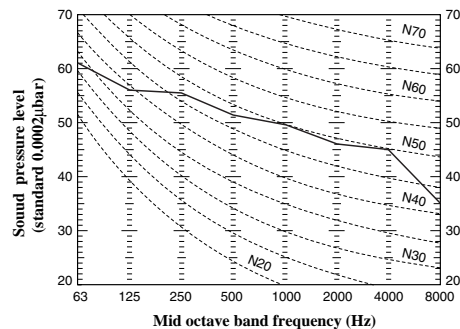

18.3 ELECTRICAL DATA

18.3.1 Electrical wiring

Model FDF508HES-SB

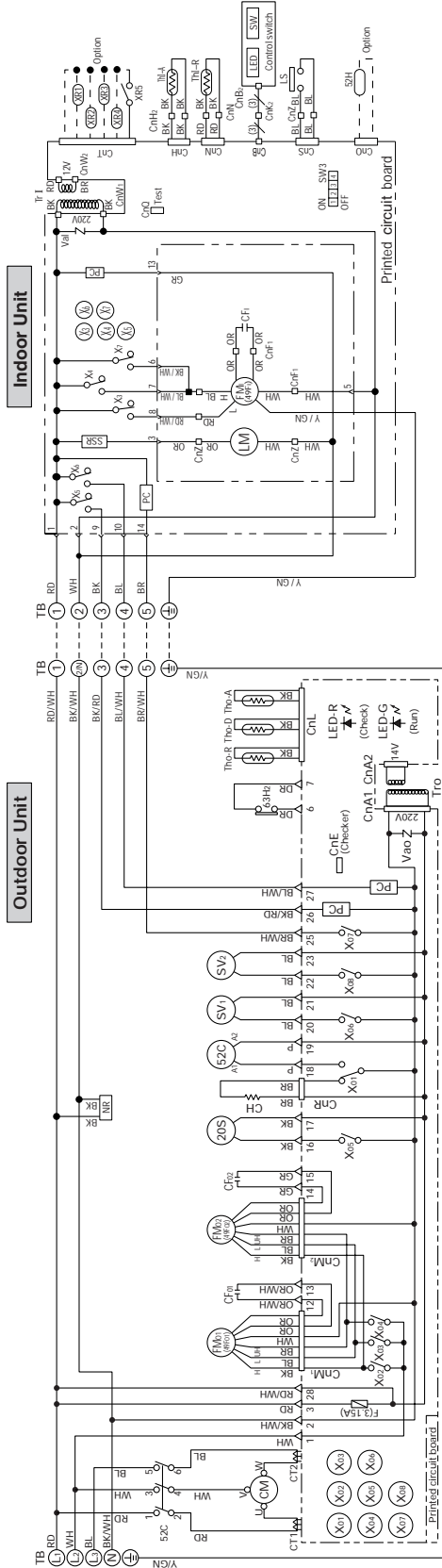

Meaning of marks

Mark	Parts name	Mark	Parts name
CF1	Capacitor for FM1	Th-R	Thermistor
CF01,2	Capacitor for FM0	Tho-A	Thermistor
CH	Crankcase heater	Tho-D	Thermistor
CM	Compressor motor	Tr1	Transformer (indoor unit)
CnA ~ Z	Connector (□ mark)	Tr0	Transformer (outdoor unit)
CT1,2	Current sensor	Var	Varistor
F	Fuse	Vao	4-way valve solenoid
FM1	Fan motor (indoor unit)	20S	Internal thermostat for FM1
FM01,2	Fan motor (outdoor unit)	49FI	Internal thermostat for FM0
LED	Indication lamp	49FO1,2	Magnetic contactor for CM
LM	Louver motor	52C	Auxiliary relay
LS	Limit switch	X3-7	Auxiliary relay
NR	Surge suppressor	X01-08	High pressure switch (for control)
SSR	Auxiliary relay (for LM)	63Hz	Terminal (F)
PC	Photo coupler	△	Connector
SV1,2	Solenoid coil (for control)	■	Indication lamp (Green)
SW1,2	Switch (ON/OFF)	LED-G	Indication lamp (Red)
SW3	Changeover switch	LED-R	
TB	Terminal block (○ mark)		
Th1-A	Thermistor		

Color mark

Mark	Color	Mark	Color
BK	Black	BK/RD	Black/Red
BL	Blue	BK/WH	Black/White
BR	Brown	BL/WH	Blue/White
GR	Gray	BR/WH	Brown/White
OR	Orange	OR/WH	Orange/White
P	Pink	RD/WH	Red/White
RD	Red	Y/GN	Yellow/Green
WH	White		

Power source
3 Phase 380V 50Hz

18.4 OUTLINE OF OPERATION CONTROL BY MICROCOMPUTER

This is same as FDUR heat pump series. Refer to page 306.

18.5 APPLICATION DATA

SAFETY PRECAUTIONS

- Please read these “Safety Precautions” first then accurately execute the installation work.
- Though the precautionary points indicated herein are divided under two headings, **⚠WARNING** and **⚠CAUTION**, those points which are related to the strong possibility of an installation done in error resulting in death or serious injury are listed in the **⚠WARNING** section. However, there is also a possibility of serious consequences in relationship to the points listed in the **⚠CAUTION** section as well.

In either case, important safety related information is indicated, so by all means, properly observe all that is mentioned.

- After completing the installation, along with confirming that no abnormalities were seen from the operation tests, please explain operating methods as well as maintenance methods to the user (customer) of this equipment, based on the owner’s manual. Moreover, ask the customer to keep this sheet together with the owner’s manual.

⚠ WARNING

- This system should be applied to places of office, restaurant, residence and the like. Application to inferior environment such as engineering shop could cause equipment malfunction.
- Please entrust installation to either the company which sold you the equipment or to a professional contractor. Defects from improper installations can be the cause of water leakage, electric shocks and fires.
- Execute the installation accurately, based on following the installation manual. Again, improper installations can result in water leakage, electric shocks and fires.
- When a large air-conditioning system is installed to a small room, it is necessary to have a prior planned countermeasure for the rare case of a refrigerant leakage, to prevent the exceeding of threshold concentration. In regards to preparing this countermeasure, consult with the company from which you purchased the equipment, and make the installation accordingly. In the rare event that a refrigerant leakage and exceeding of threshold concentration does occur, there is the danger of a resultant oxygen deficiency accident.
- For installation, confirm that the installation site can sufficiently support heavy weight. When strength is insufficient, injury can result from a falling of the unit.
- Execute the prescribed installation construction to prepare for earthquakes and the strong winds of typhoons and hurricanes, etc. Improper installations can result in accidents due to a violent falling over of the unit.
- For electrical work, please see that a licensed electrician executes the work while following the safety standards related to electrical equipment, and local regulations as well as the installation instructions, and that only exclusive use circuits are used. Insufficient power source circuit capacity and defective installment execution can be the cause of electric shocks and fires.
- Accurately connect wiring using the proper cable, and insure that the external force of the cable is not conducted to the terminal connection part, through properly securing it. Improper connection or securing can result in heat generation or fire.
- Take care that wiring does not rise upward, and accurately install the lid/service panel. Its improper installation can also result in heat generation or fire.
- When setting up or moving the location of the air conditioner, do not mix air etc. or anything other than the designated refrigerant within the refrigeration cycle. Rupture and injury caused by abnormal high pressure can result from such mixing.
- Always use accessory parts and authorized parts for installation construction. Using parts not authorized by this company can result in water leakage, electric shock, fire and refrigerant leakage.

⚠ CAUTION

- Execute proper grounding. Do not connect the ground wire to a gas pipe, water pipe, lightning rod or a telephone ground wire. Improper placement of ground wires can result in electric shock.
- The installation of an earth leakage breaker is necessary depending on the established location of the unit. Not installing an earth leakage breaker may result in electric shock.
- Do not install the unit where there is a concern about leakage of combustible gas. The rare event of leaked gas collecting around the unit could result in an outbreak of fire.
- For the drain pipe, follow the installation manual to insure that it allows proper drainage and thermally insulate it to prevent condensation. Inadequate plumbing can result in water leakage and water damage to interior items.

⚠ **NOTICE**

All Wiring of this installation must comply with NATIONAL, STATE AND LOCAL REGULATIONS. These instructions do not cover all variations for every kind of installation circumstance. Should further information be desired or should particular problems occur, the matter should be referred to Mitsubishi Heavy Industries, Ltd. through your local distributor.

⚠ **WARNING**

BE SURE TO READ THESE INSTRUCTIONS CAREFULLY BEFORE BEGINNING INSTALLATION. FAILURE TO FOLLOW THESE INSTRUCTIONS COULD CAUSE SERIOUS INJURY OR DEATH, EQUIPMENT MALFUNCTION AND/OR PROPERTY DAMAGE.

18.5.1 Installation of indoor unit

Request

- Please do not install and use the air-conditioning equipment in locations such as the following:
 - (1) In the vicinity of equipment which generates electromagnetic waves, such as that often found in hospitals, or in the vicinity of equipment which generates high frequency waves: Installation in such locations is to be avoided as the generation of electromagnetic noise can cause the controller to operate incorrectly.
 - (2) Areas which are exposed to salt air wind, such as coastal regions: Salt air can accelerate the corrosion of outer plating and the heat exchanger.
 - (3) Kitchens, machinery plants, and other similar locations where splashing and/or spraying of oil and grease occurs frequently or where a large amount of heated air is present: Grease and hot air can easily enter and disrupt the operation of the indoor unit, and thus, the unit should not be installed in such locations. In addition, these factors can also lead to reduced performance and/or corrosion of the heat exchanger as well as resulting in damage to plastic parts.
 - (4) Any location where there is a possibility that corrosive gasses (sulfurous acid, etc.) or inflammable gasses (paint thinner vapor or gasoline vapor, etc.) could be produced or could accumulate; also, installation and use of this air conditioner equipment in locations where volatile inflammable substances are handled is to be avoided: These factors can lead to corrosion of the heat exchanger and to damage to plastic parts. In addition, there is also a possibility that inflammable gasses could be ignited in the presence of the air-conditioner.
- If spatter generated during welding and other similar operations comes into contact with the indoor unit, it may result in the unit being damaged. Therefore, in addition to requesting that the utmost care be taken when performing this type of work in the vicinity of the air-conditioner equipment, it is also requested that the unit be covered to prevent spatter from passing to its interior.

⚠ CAUTION

- It is important that the following safety precautions be followed during installation of the air-conditioning equipment:
 - Do not place the air conditioner's remote control unit in any location where it will be exposed to direct sunlight as this can cause the remote control unit to be damaged or warped.
 - The equipment must be grounded; the ground wire should not be connected to either gas pipe, water pipe, lightning rod, or telephone ground wires. Incorrect operation of the air conditioner or electric shocks can result if the grounding is not performed correctly.
 - An earth leakage breaker is required to be fitted in order to provide protection against the possibility of electric shocks, fires, and other similar accidents.
 - Ensure that the air conditioner is securely installed in a location which is fully capable of supporting its weight. Failure to do so could result in a number of different problems such as the unit toppling over and causing injury or generating increased operation noise due to vibration.
 - If there is a possibility that the in-door unit's refrigerant concentration could exceed the threshold concentration (0.3 kg/m³) and result in suffocation should a leakage of this gas occur, it will be necessary to provide an opening between the room containing the indoor unit and neighboring rooms or to provide mechanical ventilating equipment which operates in response to gas leak warnings. Consult with staff at your local sales outlet when purchasing such products.

(1) Selection of a suitable installation location

(a) Installation space

The dimensions shown below are the minimum which must be available for installation of the indoor unit.

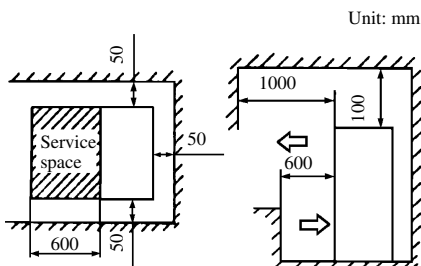

⚠ WARNING

- Install the indoor unit securely in a location which is fully capable of supporting its weight. Installing in a location which is not sufficiently reinforced or supported may result in the indoor unit toppling and falling, resulting in damage or injury.

Request

- It is important that enough space is provided for performing maintenance operations.

Request

Obtain the consent of the customer to install the indoor unit in a location which satisfies the following conditions:

- Warm and cold air must be able to dissipate freely.
- It must be possible to easily connect wiring and piping to the outdoor.
- The installation of a drain must be possible.
- The section of floor for installation must be sufficiently reinforced.
- Direct sunlight must not fall on the in-door unit.
- There must be no obstacles or blockages in the vicinity of the suction air and discharge air openings.
- There must be no possibility of faulty operation of a fire alarm, as must there be no possibility of short circuits.

(2) Transporting and installing the unit

(a) Transporting

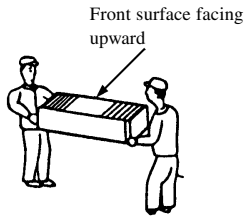

Request

- When transporting the unit to the final mounting location, keep it in its original packing as long as feasible.
- When the situation demands that the unit be unpacked for transportation, wrap using nylon sling and take care to ensure that the unit is not damaged.
Note (1) Do not hold the unit by the air inlet grill, by the air outlet grill, or by any other plastic parts.
- When placing the unit down after packaging has been removed, please ensure that it is always positioned with the front surface facing upward.

(b) Topple prevention overview

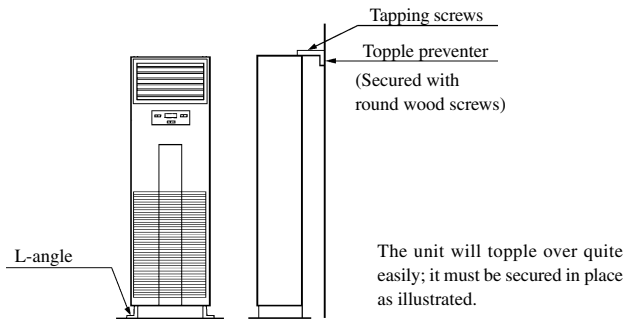

Request

- Mount the unit on a level surface; forward, backward, left, or right inclinations must not exceed 1°.

(3) Refrigerant piping Please refer to the outdoor unit's instruction manual with regard to the installation of refrigerant piping.

(a) Piping and wiring outlets

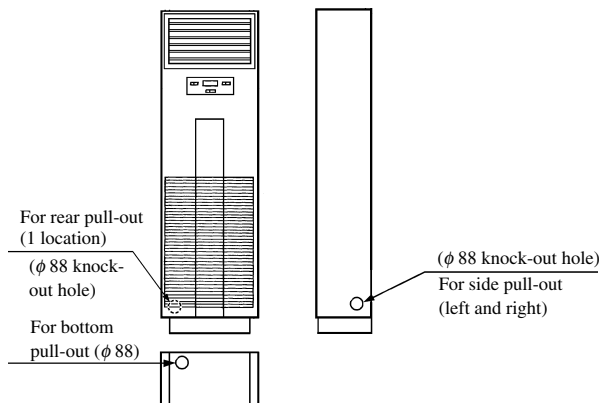

(b) Control box position and power cord path

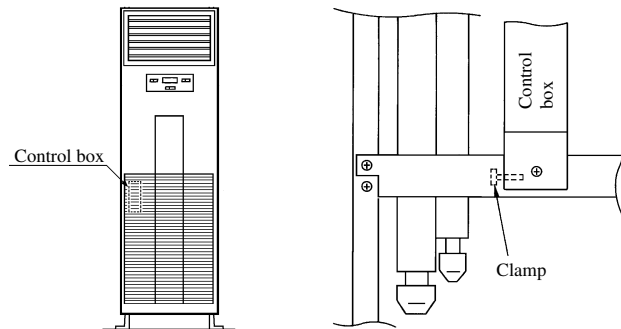

- Remove the suction grill to find the control box in the position indicated in the diagram above. Remove the cover to perform the necessary work.
- The power line must pass through the clamp and be secured by the clamp.

(4) Drain piping

WARNING

- The drain must not be allowed flow into any drainage systems where sulfurous or any other types of poisonous gas may be present as it could result in these gasses passing to the interior of the air conditioned room.

CAUTION

- Follow carefully the instructions in the installation manual to ensure that the drain is securely installed in a manner which allows free flow of water and also that it is correctly insulated to prevent condensation. Failure to install the drain correctly can lead to the leakage of water and subsequent damage to household goods.

Request

- The drain piping should be insulated to prevent the occurrence of condensation. (This applies particularly to the indoor unit itself and the unit's interior.)
- Install the piping sloping downwards (with an declination of between 1/50 and 1/100); in addition do not create any traps or rises along the length of the piping.
- Use commercially available VP-20 rigid PVC pipe for the drain piping.

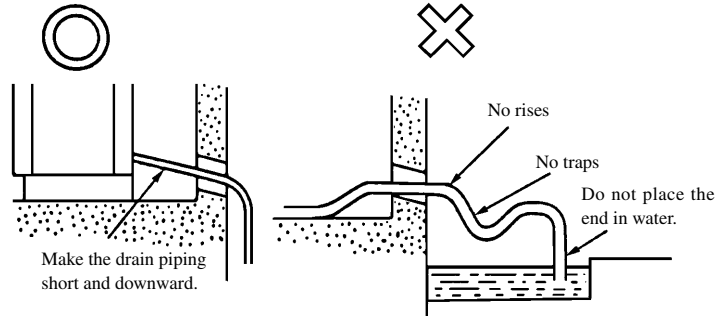

(5) Electrical wiring

- Electrical wiring operations are to be performed in accordance with the directions given in the outdoor unit's installation manual. By switching the dip switch (SW3-3) on the indoor unit printed circuit board ("Specify the following switch number."), the operation mode can be changed to the quiet mode (mild mode). Confirm at installation and change if necessary.

18.5.2 Installation of outdoor unit

This is same as FDUR heat pump series. Refer to page 330.

18.6 MAINTENANCE DATA

This is same as FDUR heat pump series. Refer to page 340.